

The protection of the **ZeroDT GB-1** utilizes **state of the art semiconductor devices**, TBUs (Transient Blocking Units) in a hybrid circuit topology to provide Ethernet (10/100 BASE-T) and Gigabit Ethernet (1000 BASE-T) devices with carrier grade surge and lightning transient protection.

The protector provides long-term system reliability by blocking the damaging transient energy to prevent damage yet remaining transparent to the data thru put of the line. The module has been tested to the Telecommunications Port Type 3 & 5, Level I & II Lightning Requirements as well as Severe Climatic Conditions as outlined in GR-1089-CORE so you can rest easy knowing your devices are well protected.

The unit does not degrade with repeated usage. The low capacitance TBUs act as 'ultra-fast disconnect switches'. When an overvoltage situation is sensed on the line, the TBU acts to 'disconnect' the equipment, and the circuitry provides a path to Ground for the damaging energy to prevent it from reaching the equipment. As soon as the voltage on the line returns to normal levels, the unit returns to its original state and allows the communications to resume unhindered, while being ready for the next overvoltage event.



▶ ELECTRICAL SPECIFICATIONS

- **Data Rates/Protocols:** 10/100/1000 Base-T (Ethernet & Gigabit Ethernet).
- **Configuration:** Series connected, protects all 8 pins.
- **Maximum Continuous Operating Voltage (MCOV):** 11 VDC.
- **Response Time:** <75 nanoseconds.
- **Maximum Surge Current, I_{peak} :**
 - **8/20 μ s (IEEE/ANSI C62.41 Combination Wave), Line-to-Ground:** >20 kA.
 - **10/1000 μ s (IEEE/ANSI C62.41 Long Wave), Line-to-Ground:** >100 Amps.
- **Maximum Capacitance per pin (L-G):** 3 pF.
- **Series Impedance (Data):** 9 Ω .

▶ MECHANICAL SPECIFICATIONS

- **Input / Output Connections:** 8P8C, RJ45 socket.
- **Module Dimensions:** 2.25" H x 2.25" W x 3.63" D (57 mm H x 57 mm W x 92 mm D).
- **Grounding/Earthing:** 1/4" x 20 stud on bottom, ring terminal provided.
- **DIN Rail Mount:** easily attached or removed from 35 mm DIN rail.

▶ ENVIRONMENTAL SPECIFICATIONS

- **Operating / Storage Temperature:** -40°C to +65°C.
- **Humidity:** 0 to 95% non-condensing.

▶ CERTIFICATIONS

- **Module mounted in the enclosure meets the requirements of:**
 - Hazardous Locations - Class I, Division 2, Groups A, B, C, D T6
 - Ordinary locations - UL 497A
 - ETL 60950-1



► DIMENSIONAL DRAWINGS

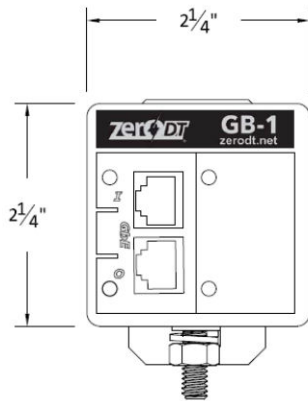

FRONT VIEW

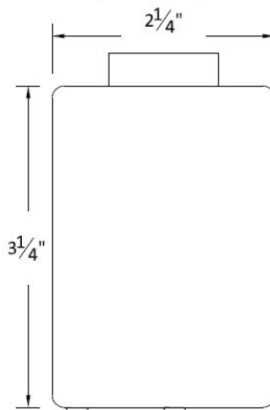

TOP VIEW

WARNING
EXPLOSION HAZARD:
Do not disconnect equipment while the circuit is live or unless the area is known to be free of ignitable concentrations.

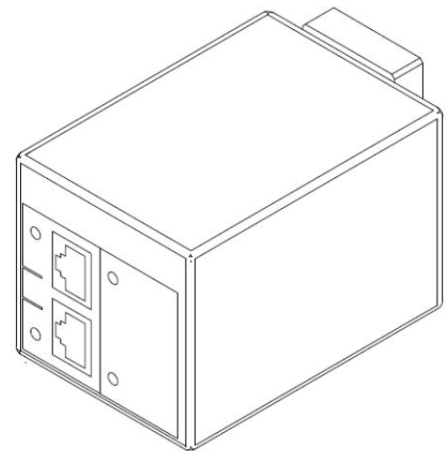

ISOMETRIC VIEW

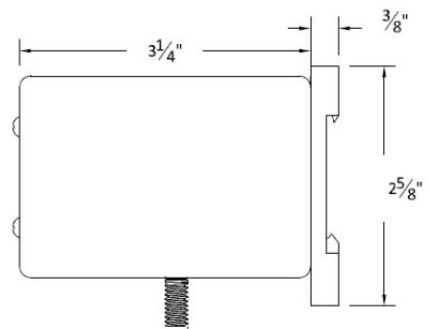

SIDE VIEW

► INSTALLATION PROCEDURE

Suppressor must be Grounded for proper operation !

1. For maximum overvoltage protection, mount the ZeroDT GB-1 as close as possible to the equipment to be protected.
2. The ZeroDT GB-1 unit is to be installed in accordance with the applicable requirements of the National Electric Code and the local authorities having jurisdiction.
3. The unit **MUST BE PROPERLY BONDED TO A LOW RESISTANCE EARTH/GROUND FOR PROPER OVERVOLTAGE PROTECTION.** Install the Earth/Ground connection using the ring terminal provide (or similar) on the 1/4" x 20 stud on the bottom of the unit with the supplied fasteners.
4. Connect the incoming data line (10/100, or 10/1000 BT) to the RJ45 connector labeled 'I' on the module. This is the "Surge" or Field side.
5. Connect the data line going to/from the protected equipment to the RJ45 connector labeled 'O' on the module. This is the "Protected" side.
6. In the unlikely event that the ZeroDT GB-1 self-sacrifices, the suppressor will interrupt communications.

This equipment is suitable for use in Class I, Div. 2, Gr. A, B, C, or D (T6) as well as in non-hazardous locations.